

DETAIL A  
2:1

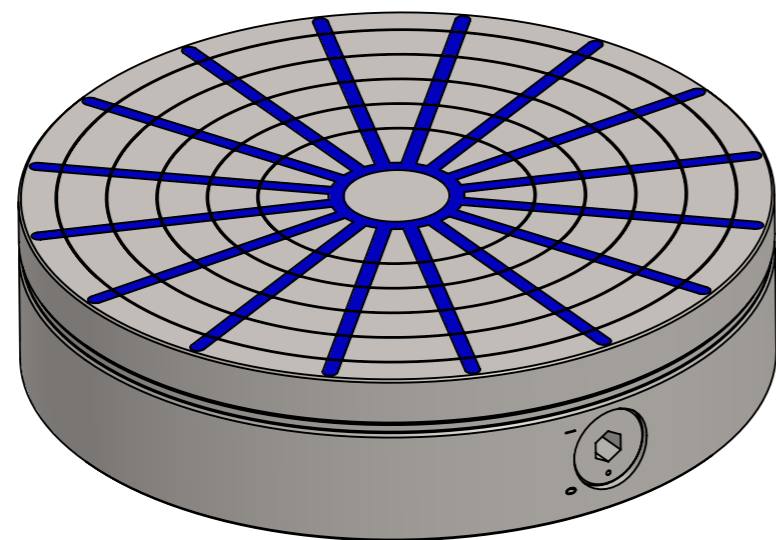

Schutzvermerk nach DIN ISO 16016 beachten! Nachdruck nur mit unserer Genehmigung!				3,2 $\nabla$ $\begin{matrix} -0,05 \\ -0,2 \end{matrix}$	tolerance	material:	weight: 40.50
All rights reserved according to DIN ISO 16016! Reprint with our permission only!					ISO 7168 M	drawing no.:	0019444
		date	name		description: <b>RS 30 Magnetrundfutter</b>		
		drawn	27.03.2024	TW			
		appr.	27.03.2024	TW			
		 www.flraig-te.de			part no.:	210330	sheet 1 / 2
rev.	change	date	name		scale: 1:2.5	Status: Freigegeben	

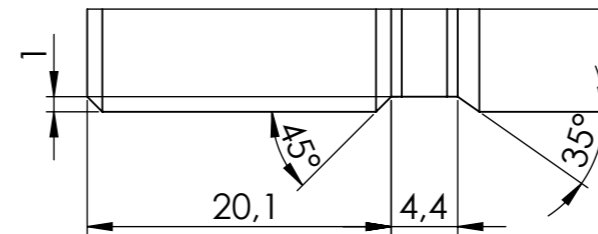
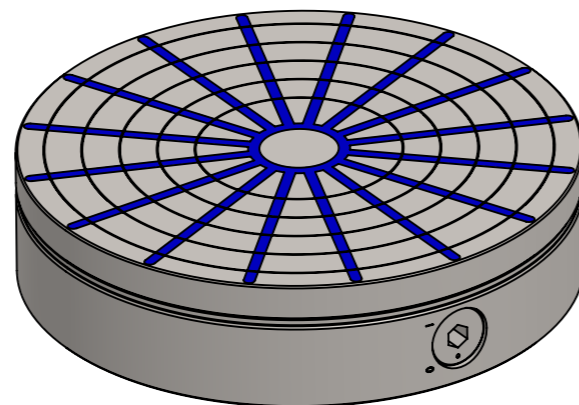
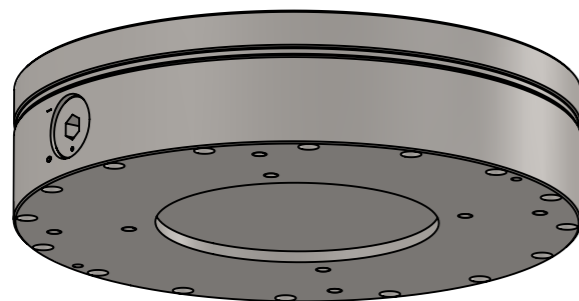
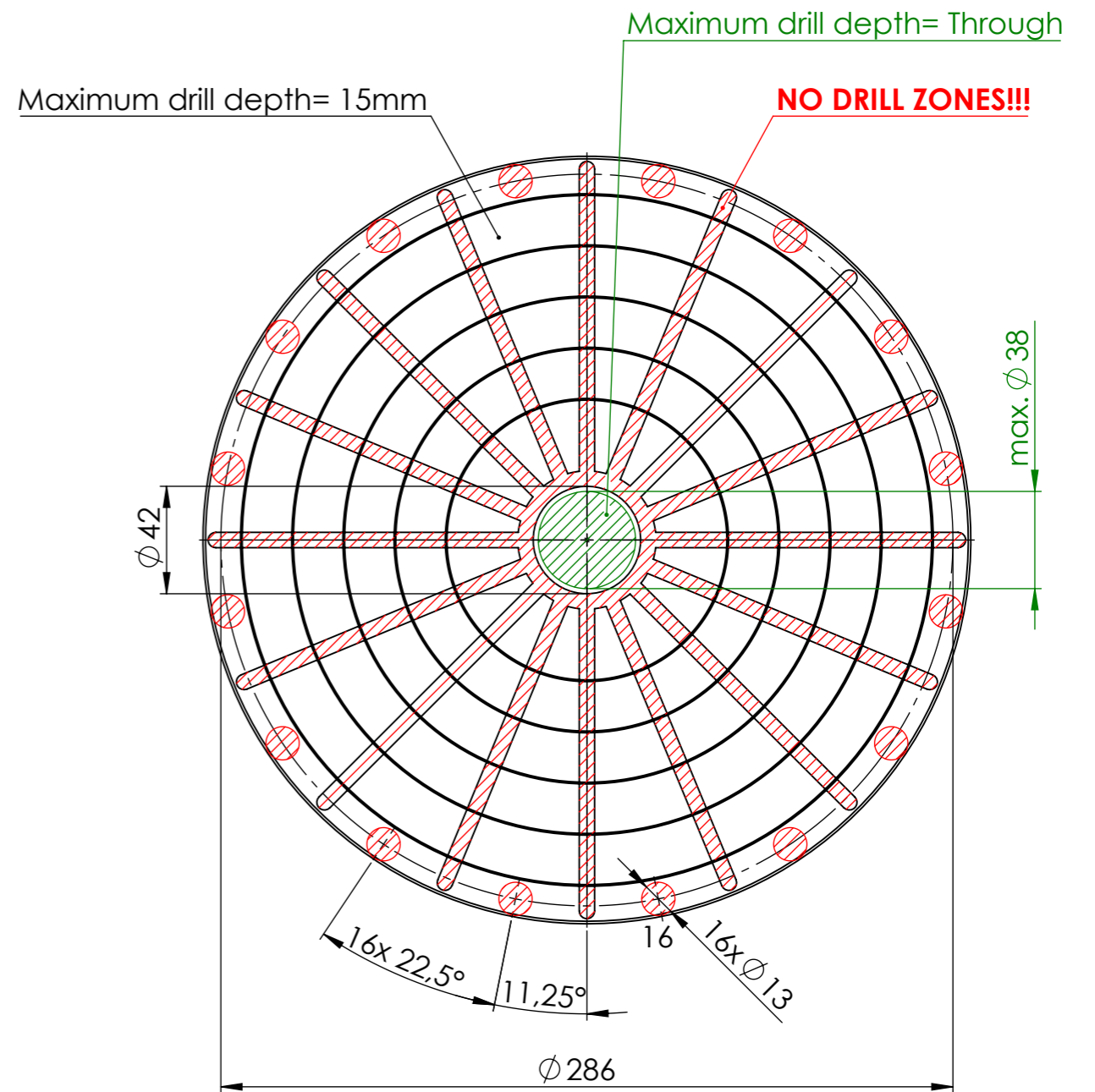
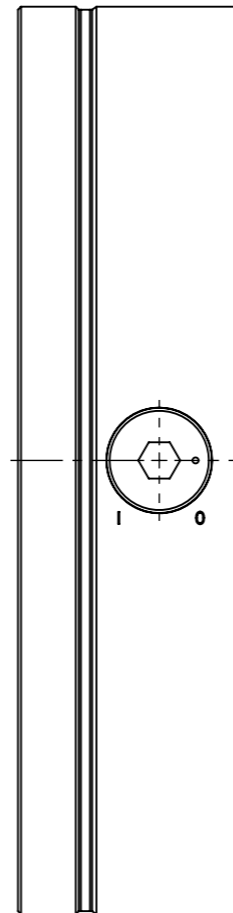
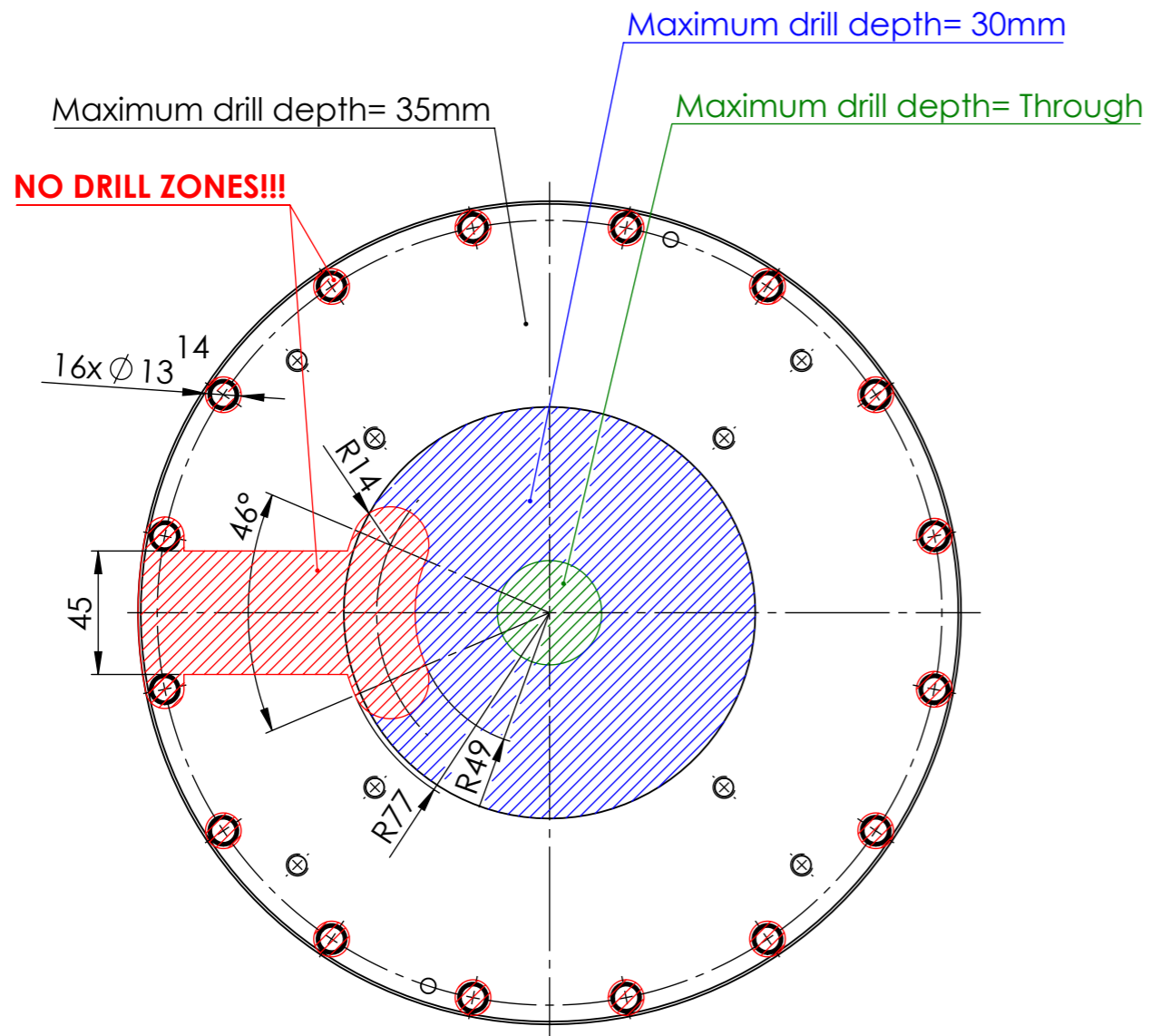

Schutzvermerk nach DIN ISO 16016 beachten! Nachdruck nur mit unserer Genehmigung!				3,2 / -0,05 / -0,2	tolerance	material:	weight: 40.50
All rights reserved according to DIN ISO 16016! Reprint with our permission only!					ISO 7168 M	drawing no.:	<b>0019444</b>
				date	name	description: <b>RS 30 Magnetrundfutter</b>	
				drawn 27.03.2024	TW		
				edit 27.03.2024			
				appr. 27.03.2024	TW		
				 www.flraig-te.de		part no.:	sheet 2 / 2
						210330	A3
rev.	change	date	name	scale: 1:2.5		Status: Freigegeben	